

Internet Engineering Task Force (IETF)
Request for Comments: 7062
Category: Informational
ISSN: 2070-1721

F. Zhang, Ed.
D. Li
Huawei
H. Li
CMCC
S. Belotti
Alcatel-Lucent
D. Ceccarelli
Ericsson
November 2013

Framework for GMPLS and PCE Control of
G.709 Optical Transport Networks

Abstract

This document provides a framework to allow the development of protocol extensions to support Generalized Multi-Protocol Label Switching (GMPLS) and Path Computation Element (PCE) control of Optical Transport Networks (OTNs) as specified in ITU-T Recommendation G.709 as published in 2012.

Status of This Memo

This document is not an Internet Standards Track specification; it is published for informational purposes.

This document is a product of the Internet Engineering Task Force (IETF). It represents the consensus of the IETF community. It has received public review and has been approved for publication by the Internet Engineering Steering Group (IESG). Not all documents approved by the IESG are a candidate for any level of Internet Standard; see Section 2 of RFC 5741.

Information about the current status of this document, any errata, and how to provide feedback on it may be obtained at <http://www.rfc-editor.org/info/rfc7062>.

Copyright Notice

Copyright (c) 2013 IETF Trust and the persons identified as the document authors. All rights reserved.

This document is subject to BCP 78 and the IETF Trust's Legal Provisions Relating to IETF Documents (<http://trustee.ietf.org/license-info>) in effect on the date of publication of this document. Please review these documents carefully, as they describe your rights and restrictions with respect to this document. Code Components extracted from this document must include Simplified BSD License text as described in Section 4.e of the Trust Legal Provisions and are provided without warranty as described in the Simplified BSD License.

Table of Contents

1. Introduction	3
2. Terminology	3
3. G.709 Optical Transport Network	4
3.1. OTN Layer Network	5
3.1.1. Client Signal Mapping	6
3.1.2. Multiplexing ODUj onto Links	7
3.1.2.1. Structure of MSI Information	9
4. Connection Management in OTN	10
4.1. Connection Management of the ODU	11
5. GMPLS/PCE Implications	13
5.1. Implications for Label Switched Path (LSP) Hierarchy	13
5.2. Implications for GMPLS Signaling	14
5.3. Implications for GMPLS Routing	16
5.4. Implications for Link Management Protocol	18
5.5. Implications for Control-Plane Backward Compatibility	19
5.6. Implications for Path Computation Elements	20
5.7. Implications for Management of GMPLS Networks	20
6. Data-Plane Backward Compatibility Considerations	21
7. Security Considerations	21
8. Acknowledgments	22
9. Contributors	22
10. References	23
10.1. Normative References	23
10.2. Informative References	24

1. Introduction

Optical Transport Networks (OTNs) have become a mainstream layer 1 technology for the transport network. Operators want to introduce control-plane capabilities based on GMPLS to OTN to realize the benefits associated with a high-function control plane (e.g., improved network resiliency, resource usage efficiency, etc.).

GMPLS extends Multi-Protocol Label Switching (MPLS) to encompass Time Division Multiplexing (TDM) networks (e.g., Synchronous Optical NETwork (SONET) / Synchronous Digital Hierarchy (SDH), Plesiochronous Digital Hierarchy (PDH), and G.709 sub-lambda), lambda switching optical networks, and spatial switching (e.g., incoming port or fiber to outgoing port or fiber). The GMPLS architecture is provided in [RFC3945], signaling function and Resource Reservation Protocol - Traffic Engineering (RSVP-TE) extensions are described in [RFC3471] and [RFC3473], routing and Open Shortest Path First (OSPF) extensions are described in [RFC4202] and [RFC4203], and the Link Management Protocol (LMP) is described in [RFC4204].

The GMPLS signaling extensions defined in [RFC4328] provide the mechanisms for basic GMPLS control of OTN based on the 2001 revision of the G.709 specification. The 2012 revision of the G.709 specification, [G709-2012], includes new features, for example, various multiplexing structures, two types of Tributary Slots (TSs) (i.e., 1.25 Gbps and 2.5G bps), and extension of the Optical channel Data Unit-j (ODUj) definition to include the ODUflex function.

This document reviews relevant aspects of OTN technology evolution that affect the GMPLS control-plane protocols and examines why and how to update the mechanisms described in [RFC4328]. This document additionally provides a framework for GMPLS control of OTN and includes a discussion of the implications for the use of the PCE [RFC4655].

For the purposes of the control plane, the OTN can be considered to be comprised of ODU and wavelength (Optical Channel (OCh)) layers. This document focuses on the control of the ODU layer, with control of the wavelength layer considered out of the scope. Please refer to [RFC6163] for further information about the wavelength layer.

2. Terminology

OTN: Optical Transport Network

OPU: Optical Channel Payload Unit

ODU: Optical Channel Data Unit

OTU: Optical Channel Transport Unit

OMS: Optical Multiplex Section

MSI: Multiplex Structure Identifier

TPN: Tributary Port Number

LO ODU: Lower Order ODU. The LO ODU_j (j can be 0, 1, 2, 2e, 3, 4, or flex) represents the container transporting a client of the OTN that is either directly mapped into an OTU_k (k = j) or multiplexed into a server HO ODU_k (k > j) container.

HO ODU: Higher Order ODU. The HO ODU_k (k can be 1, 2, 2e, 3, or 4) represents the entity transporting a multiplex of LO ODU_j tributary signals in its OPU_k area.

ODUflex: Flexible ODU. A flexible ODU_k can have any bit rate and a bit rate tolerance of +/-100 ppm (parts per million).

In general, throughout this document, "ODU_j" is used to refer to ODU entities acting as an LO ODU, and "ODU_k" is used to refer to ODU entities being used as an HO ODU.

3. G.709 Optical Transport Network

This section provides an informative overview of the aspects of the OTN impacting control-plane protocols. This overview is based on the ITU-T Recommendations that contain the normative definition of the OTN. Technical details regarding OTN architecture and interfaces are provided in the relevant ITU-T Recommendations.

Specifically, [G872-2012] describes the functional architecture of optical transport networks providing optical signal transmission, multiplexing, routing, supervision, performance assessment, and network survivability. The legacy OTN referenced by [RFC4328] defines the interfaces of the optical transport network to be used within and between subnetworks of the optical network. With the evolution and deployment of OTN technology, many new features have been specified in ITU-T recommendations, including, for example, new ODU₀, ODU_{2e}, ODU₄, and ODUflex containers as described in [G709-2012].

3.1. OTN Layer Network

The simplified signal hierarchy of OTN is shown in Figure 1, which illustrates the layers that are of interest to the control plane. Other layers below OCh (e.g., Optical Transmission Section (OTS)) are not included in this figure. The full signal hierarchy is provided in [G709-2012].

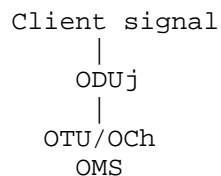

Figure 1: Basic OTN Signal Hierarchy

Client signals are mapped into ODUj containers. These ODUj containers are multiplexed onto the OTU/OCh. The individual OTU/OCh signals are combined in the OMS using Wavelength Division Multiplexing (WDM), and this aggregated signal provides the link between the nodes.

3.1.1.1. Client Signal Mapping

The client signals are mapped into an LO ODU_j. The current values of *j* defined in [G709-2012] are: 0, 1, 2, 2e, 3, 4, and flex. The approximate bit rates of these signals are defined in [G709-2012] and are reproduced in Tables 1 and 2.

ODU Type	ODU nominal bit rate
ODU0	1,244,160 Kbps
ODU1	239/238 x 2,488,320 Kbps
ODU2	239/237 x 9,953,280 Kbps
ODU3	239/236 x 39,813,120 Kbps
ODU4	239/227 x 99,532,800 Kbps
ODU2e	239/237 x 10,312,500 Kbps
ODUflex for Constant Bit Rate (CBR) Client signals	239/238 x client signal bit rate
ODUflex for Generic Framing Procedure - Framed (GFP-F) Mapped client signal	Configured bit rate

Table 1: ODU Types and Bit Rates

NOTE: The nominal ODU_k rates are approximately: 2,498,775.126 Kbps (ODU1), 10,037,273.924 Kbps (ODU2), 40,319,218.983 Kbps (ODU3), 104,794,445.815 Kbps (ODU4), and 10,399,525.316 Kbps (ODU2e).

ODU Type	ODU bit rate tolerance
ODU0	+/-20 ppm
ODU1	+/-20 ppm
ODU2	+/-20 ppm
ODU3	+/-20 ppm
ODU4	+/-20 ppm
ODU2e	+/-100 ppm
ODUflex for CBR Client signals	+/-100 ppm
ODUflex for GFP-F Mapped client signal	+/-100 ppm

Table 2: ODU Types and Tolerance

One of two options is for mapping client signals into ODUflex depending on the client signal type:

- Circuit clients are proportionally wrapped. Thus, the bit rate is defined by the client signal, and the tolerance is fixed to +/-100 ppm.
- Packet clients are mapped using the Generic Framing Procedure (GFP). [G709-2012] recommends that the ODUflex(GFP) will fill an integral number of tributary slots of the smallest HO ODUk path over which the ODUflex(GFP) may be carried, and the tolerance should be +/-100 ppm.

Note that additional information on G.709 client mapping can be found in [G7041].

3.1.2. Multiplexing ODUj onto Links

The links between the switching nodes are provided by one or more wavelengths. Each wavelength carries one OCh, which carries one OTU, which carries one ODU. Since all of these signals have a 1:1:1 relationship, we only refer to the OTU for clarity. The ODUjs are mapped into the TSs (Tributary Slots) of the OPUk. Note that in the case where j=k, the ODUj is mapped into the OTU/OCh without multiplexing.

The initial versions of G.709 referenced by [RFC4328] only provided a single TS granularity, nominally 2.5 Gbps. [G709-2012] added an additional TS granularity, nominally 1.25 Gbps. The number and type of TS provided by each of the currently identified OTUk are provided below:

	Tributary Slot Granularity		Nominal Bit Rate
	2.5 Gbps	1.25 Gbps	
OTU1	1	2	2.5 Gbps
OTU2	4	8	10 Gbps
OTU3	16	32	40 Gbps
OTU4	--	80	100 Gbps

To maintain backward compatibility while providing the ability to interconnect nodes that support a 1.25 Gbps TS at one end of a link and a 2.5 Gbps TS at the other, [G709-2012] requires 'new' equipment to fall back to the use of a 2.5 Gbps TS when connected to legacy equipment. This information is carried in band by the payload type.

The actual bit rate of the TS in an OTUk depends on the value of k. Thus, the number of TSs occupied by an ODUj may vary depending on the values of j and k. For example, an ODU2e uses 9 TSs in an OTU3 but only 8 in an OTU4. Examples of the number of TSs used for various cases are provided below (referring to Tables 7-9 of [G709-2012]):

- ODU0 into ODU1, ODU2, ODU3, or ODU4 multiplexing with 1.25 Gbps TS granularity
 - o ODU0 occupies 1 of the 2, 8, 32, or 80 TSs for ODU1, ODU2, ODU3, or ODU4
- ODU1 into ODU2, ODU3, or ODU4 multiplexing with 1.25 Gbps TS granularity
 - o ODU1 occupies 2 of the 8, 32, or 80 TSs for ODU2, ODU3, or ODU4
- ODU1 into ODU2 or ODU3 multiplexing with 2.5 Gbps TS granularity
 - o ODU1 occupies 1 of the 4 or 16 TSs for ODU2 or ODU3
- ODU2 into ODU3 or ODU4 multiplexing with 1.25 Gbps TS granularity
 - o ODU2 occupies 8 of the 32 or 80 TSs for ODU3 or ODU4
- ODU2 into ODU3 multiplexing with 2.5 Gbps TS granularity
 - o ODU2 occupies 4 of the 16 TSs for ODU3
- ODU3 into ODU4 multiplexing with 1.25 Gbps TS granularity
 - o ODU3 occupies 31 of the 80 TSs for ODU4

- ODUflex into ODU2, ODU3, or ODU4 multiplexing with 1.25 Gbps TS granularity
 - o ODUflex occupies n of the 8, 32, or 80 TSs for ODU2, ODU3, or ODU4 ($n \leq$ Total TS number of ODU k)
- ODU2e into ODU3 or ODU4 multiplexing with 1.25 Gbps TS granularity
 - o ODU2e occupies 9 of the 32 TSs for ODU3 or 8 of the 80 TSs for ODU4

In general, the mapping of an ODU j (including ODUflex) into a specific OTU k TS is determined locally, and it can also be explicitly controlled by a specific entity (e.g., head end or Network Management System (NMS)) through Explicit Label Control [RFC3473].

3.1.2.1. Structure of MSI Information

When multiplexing an ODU j into an HO ODU k ($k > j$), G.709 specifies the information that has to be transported in-band in order to allow for correct demultiplexing. This information, known as MSI, is transported in the OPU k overhead and is local to each link. In case of bidirectional paths, the association between the TPN and TS must be the same in both directions.

The MSI information is organized as a set of entries, with one entry for each HO ODU j TS. The information carried by each entry is:

- Payload Type: the type of the transported payload.
- TPN: the port number of the ODU j transported by the HO ODU k . The TPN is the same for all the TSs assigned to the transport of the same ODU j instance.

For example, an ODU2 carried by an HO ODU3 is described by 4 entries in the OPU3 overhead when the TS granularity is 2.5 Gbps, and by 8 entries when the TS granularity is 1.25 Gbps.

On each node and on every link, two MSI values have to be provisioned (referring to [G798]):

- The Transmitted MSI (TxMSI) information inserted in OPU (e.g., OPU3) overhead by the source of the HO ODU k trail.
- The Expected MSI (ExMSI) information that is used to check the Accepted MSI (AcMSI) information. The AcMSI information is the MSI valued received in-band, after a three-frame integration.

As described in [G798], the sink of the HO ODU trail checks the complete content of the AcMSI information against the ExMSI. If the AcMSI is different from the ExMSI, then the traffic is dropped, and a payload mismatch alarm is generated.

Provisioning of TPN can be performed by either a network management system or control plane. In the last case, the control plane is also responsible for negotiating the provisioned values on a link-by-link basis.

4. Connection Management in OTN

OTN-based connection management is concerned with controlling the connectivity of ODU paths and OCh. This document focuses on the connection management of ODU paths. The management of OCh paths is described in [RFC6163].

While [G872-2001] considered the ODU to be a set of layers in the same way as SDH has been modeled, recent ITU-T OTN architecture progress [G872-2012] includes an agreement to model the ODU as a single-layer network with the bit rate as a parameter of links and connections. This allows the links and nodes to be viewed in a single topology as a common set of resources that are available to provide ODU_j connections independent of the value of j. Note that when the bit rate of ODU_j is less than the server bit rate, ODU_j connections are supported by HO ODU (which has a one-to-one relationship with the OTU).

From an ITU-T perspective, the ODU connection topology is represented by that of the OTU link layer, which has the same topology as that of the OCh layer (independent of whether the OTU supports an HO ODU, where multiplexing is utilized, or an LO ODU in the case of direct mapping).

Thus, the OTU and OCh layers should be visible in a single topological representation of the network, and from a logical perspective, the OTU and OCh may be considered as the same logical, switchable entity.

Note that the OTU link-layer topology may be provided via various infrastructure alternatives, including point-to-point optical connections, optical connections fully in the optical domain, and optical connections involving hybrid sub-lambda/lambda nodes involving 3R, etc. See [RFC6163] for additional information.

4.1. Connection Management of the ODU

An LO ODU_j can be either mapped into the OTU_k signal ($j = k$) or multiplexed with other LO ODU_js into an OTU_k ($j < k$), and the OTU_k is mapped into an OCh.

From the perspective of the control plane, there are two kinds of network topology to be considered.

(1) ODU layer

In this case, the ODU links are presented between adjacent OTN nodes, as illustrated in Figure 2. In this layer, there are ODU links with a variety of TSSs available, and nodes that are Optical Digital Cross Connects (ODXCs). LO ODU connections can be set up based on the network topology.

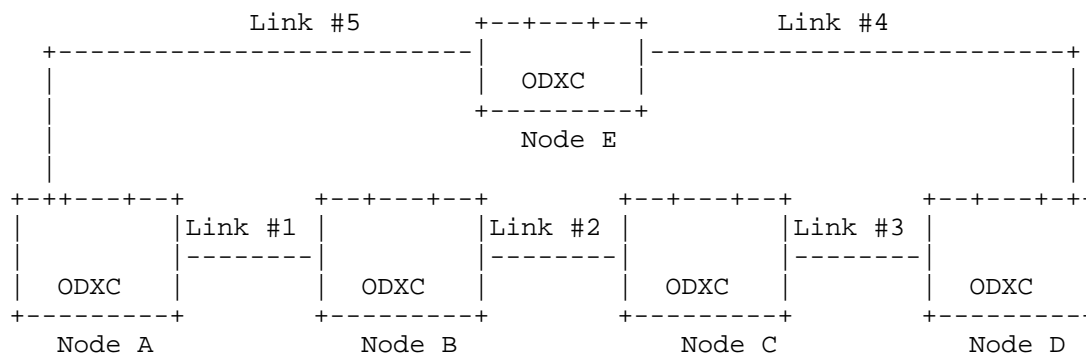

Figure 2: Example Topology for LO ODU Connection Management

If an ODU_j connection is requested between Node C and Node E, routing/path computation must select a path that has the required number of TSSs available and that offers the lowest cost. Signaling is then invoked to set up the path and to provide the information (e.g., selected TSSs) required by each transit node to allow the configuration of the ODU_j-to-OTU_k mapping ($j = k$) or multiplexing ($j < k$) and demapping ($j = k$) or demultiplexing ($j < k$).

(2) ODU layer with OCh switching capability

In this case, the OTN nodes interconnect with wavelength switched nodes (e.g., Reconfiguration Optical Add/Drop Multiplexer (ROADM) or Optical Cross-Connect (OXC)) that are capable of OCh switching; this is illustrated in Figures 3 and 4. There are the ODU layer and the OCh layer, so it is simply a Multi-Layer Network (MLN) (see

[RFC6001]). OCh connections may be created on demand, which is described in Section 5.1.

In this case, an operator may choose to allow the underlying OCh layer to be visible to the ODU routing/path computation process, in which case the topology would be as shown in Figure 4. In Figure 3, however, a cloud representing OCh-capable switching nodes is represented. In Figure 3, the operator choice is to hide the real OCh-layer network topology.

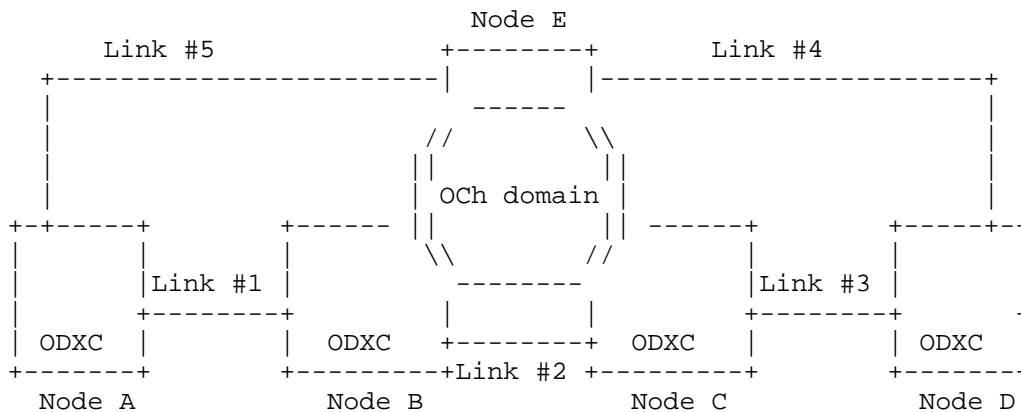

Figure 3: OCh Hidden Topology for LO ODU Connection Management

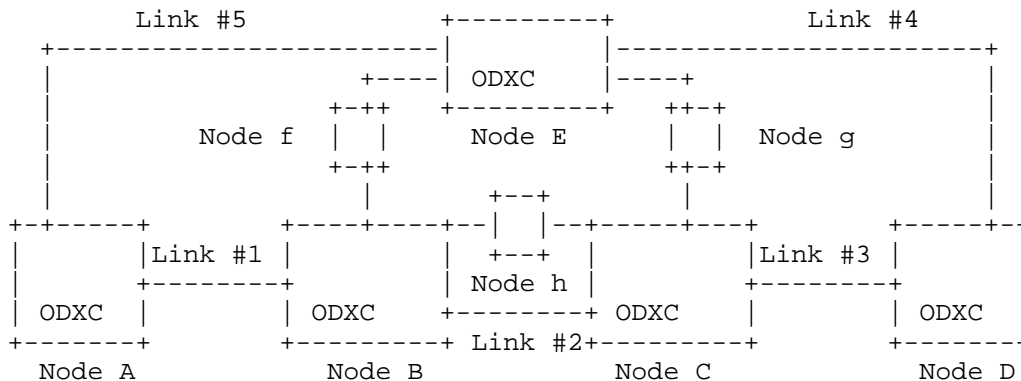

Figure 4: OCh Visible Topology for LO ODUj Connection Management

In Figure 4, the cloud in the previous figure is substituted by the real topology. The nodes f, g, and h are nodes with OCh switching capability.

In the examples (i.e., Figures 3 and 4), we have considered the case in which LO ODUj connections are supported by an OCh connection and the case in which the supporting underlying connection can also be made by a combination of HO ODU/OCh connections.

In this case, the ODU routing/path selection process will request an HO ODU/OCh connection between node C and node E from the OCh domain. The connection will appear at the ODU level as a Forwarding Adjacency, which will be used to create the ODU connection.

5. GMPLS/PCE Implications

The purpose of this section is to provide a set of requirements to be evaluated for extensions of the current GMPLS protocol suite and the PCE applications and protocols to encompass OTN enhancements and connection management.

5.1. Implications for Label Switched Path (LSP) Hierarchy

The path computation for an ODU connection request is based on the topology of the ODU layer.

The OTN path computation can be divided into two layers. One layer is OCh/OTUk; the other is ODUj. [RFC4206] and [RFC6107] define the mechanisms to accomplish creating the hierarchy of LSPs. The LSP management of multiple layers in OTN can follow the procedures defined in [RFC4206], [RFC6001], and [RFC6107].

As discussed in Section 4, the route path computation for OCh is in the scope of the Wavelength Switched Optical Network (WSO) [RFC6163]. Therefore, this document only considers the ODU layer for an ODU connection request.

The LSP hierarchy can also be applied within the ODU layers. One of the typical scenarios for ODU layer hierarchy is to maintain compatibility with introducing new [G709-2012] services (e.g., ODU0 and ODUflex) into a legacy network configuration (i.e., the legacy OTN referenced by [RFC4328]). In this scenario, it may be necessary to consider introducing hierarchical multiplexing capability in specific network transition scenarios. One method for enabling multiplexing hierarchy is by introducing dedicated boards in a few specific places in the network and tunneling these new services through the legacy containers (ODU1, ODU2, ODU3), thus postponing the need to upgrade every network element to [G709-2012] capabilities.

In such cases, one ODU_j connection can be nested into another ODU_k ($j < k$) connection, which forms the LSP hierarchy in the ODU layer. The creation of the outer ODU_k connection can be triggered via network planning or by the signaling of the inner ODU_j connection. For the former case, the outer ODU_k connection can be created in advance based on network planning. For the latter case, the multi-layer network signaling described in [RFC4206], [RFC6107], and [RFC6001] (including related modifications, if needed) is relevant to create the ODU connections with multiplexing hierarchy. In both cases, the outer ODU_k connection is advertised as a Forwarding Adjacency (FA).

5.2. Implications for GMPLS Signaling

The signaling function and RSVP-TE extensions are described in [RFC3471] and [RFC3473]. For OTN-specific control, [RFC4328] defines signaling extensions to support control for the legacy G.709 Optical Transport Networks.

As described in Section 3, [G709-2012] introduced some new features that include the ODU0, ODU2e, ODU4, and ODUFlex containers. The mechanisms defined in [RFC4328] do not support such new OTN features, and protocol extensions will be necessary to allow them to be controlled by a GMPLS control plane.

[RFC4328] defines the LSP Encoding Type, the Switching Type, and the Generalized Protocol Identifier (Generalized-PID) constituting the common part of the Generalized Label Request. The G.709 traffic parameters are also defined in [RFC4328]. In addition, the following signaling aspects not included in [RFC4328] should be considered:

- Support for specifying new signal types and related traffic information

The traffic parameters should be extended in a signaling message to support the new ODU_j, including:

- ODU0
- ODU2e
- ODU4
- ODUFlex

For the ODUFlex signal type, the bit rate must be carried additionally in the traffic parameter to set up an ODUFlex connection.

For other ODU signal types, the bit rates and tolerances are fixed and can be deduced from the signal types.

- Support for LSP setup using different TS granularity

The signaling protocol should be able to identify the TS granularity (i.e., the 2.5 Gbps TS granularity and the new 1.25 Gbps TS granularity) to be used for establishing a Hierarchical LSP that will be used to carry service LSP(s) requiring a specific TS granularity.

- Support for LSP setup of new ODUk/ODUflex containers with related mapping and multiplexing capabilities

A new label format must be defined to carry the exact TS's allocation information related to the extended mapping and multiplexing hierarchy (for example, ODU0 into ODU2 multiplexing (with 1.25 Gbps TS granularity)), in order to set up the ODU connection.

- Support for TPN allocation and negotiation

TPN needs to be configured as part of the MSI information (see more information in Section 3.1.2.1). A signaling mechanism must be identified to carry TPN information if the control plane is used to configure MSI information.

- Support for ODU Virtual Concatenation (VCAT) and Link Capacity Adjustment Scheme (LCAS)

GMPLS signaling should support the creation of Virtual Concatenation of an ODUk signal with $k=1, 2, 3$. The signaling should also support the control of dynamic capacity changing of a VCAT container using LCAS ([G7042]). [RFC6344] has a clear description of VCAT and LCAS control in SONET/SDH and OTN.

- Support for Control of Hitless Adjustment of ODUflex (GFP)

[G7044] has been created in ITU-T to specify hitless adjustment of ODUflex (GFP) (HAO) that is used to increase or decrease the bandwidth of an ODUflex (GFP) that is transported in an OTN.

The procedure of ODUflex (GFP) adjustment requires the participation of every node along the path. Therefore, it is recommended to use control-plane signaling to initiate the adjustment procedure in order to avoid manual configuration at each node along the path.

From the perspective of the control plane, control of ODUflex resizing is similar to control of bandwidth increasing and decreasing as described in [RFC3209]. Therefore, the Shared Explicit (SE) style can be used for control of HAO.

All the extensions above should consider the extensibility to match future evolution of OTN.

5.3. Implications for GMPLS Routing

The path computation process needs to select a suitable route for an ODUj connection request. In order to perform the path computation, it needs to evaluate the available bandwidth on each candidate link. The routing protocol should be extended to convey sufficient information to represent ODU Traffic Engineering (TE) topology.

The Interface Switching Capability Descriptors defined in [RFC4202] present a new constraint for LSP path computation. [RFC4203] defines the Switching Capability, related Maximum LSP Bandwidth, and Switching Capability specific information. When the Switching Capability field is TDM, the Switching Capability specific information field includes Minimum LSP Bandwidth, an indication whether the interface supports Standard or Arbitrary SONET/SDH, and padding. Hence, a new Switching Capability value needs to be defined for [G709-2012] ODU switching in order to allow the definition of a new Switching Capability specific information field. The following requirements should be considered:

- Support for carrying the link multiplexing capability

As discussed in Section 3.1.2, many different types of ODUj can be multiplexed into the same OTUk. For example, both ODU0 and ODU1 may be multiplexed into ODU2. An OTU link may support one or more types of ODUj signals. The routing protocol should be capable of carrying this multiplexing capability.

- Support any ODU and ODUflex

The bit rate (i.e., bandwidth) of each TS is dependent on the TS granularity and the signal type of the link. For example, the bandwidth of a 1.25 Gbps TS in an OTU2 is about 1.249409620 Gbps, while the bandwidth of a 1.25 Gbps TS in an OTU3 is about 1.254703729 Gbps.

One LO ODU may need a different number of TSs when multiplexed into different HO ODUs. For example, for ODU2e, 9 TSs are needed when multiplexed into an ODU3, while only 8 TSs are needed when

multiplexed into an ODU4. For ODUflex, the total number of TSs to be reserved in an HO ODU equals the maximum of [bandwidth of ODUflex / bandwidth of TS of the HO ODU].

Therefore, the routing protocol should be capable of carrying the necessary link bandwidth information for performing accurate route computation for any of the fixed rate ODUs as well as ODUflex.

- Support for differentiating between terminating and switching capability

Due to internal constraints and/or limitations, the type of signal being advertised by an interface could be restricted to switched (i.e., forwarded to switching matrix without multiplexing/demultiplexing actions), restricted to terminated (demuxed), or both. The capability advertised by an interface needs further distinction in order to separate termination and switching capabilities.

Therefore, to allow the required flexibility, the routing protocol should clearly distinguish the terminating and switching capability.

- Support for Tributary Slot Granularity advertisement

[G709-2012] defines two types of TSs, but each link can only support a single type at a given time. In order to perform a correct path computation (i.e., the LSP endpoints have matching Tributary Slot Granularity values) the Tributary Slot Granularity needs to be advertised.

- Support different priorities for resource reservation

How many priority levels should be supported depends on the operator's policy. Therefore, the routing protocol should be capable of supporting up to 8 priority levels as defined in [RFC4202].

- Support link bundling

As described in [RFC4201], link bundling can improve routing scalability by reducing the number of TE links that have to be handled by the routing protocol. The routing protocol should be capable of supporting the bundling of multiple OTU links, at the same line rate and muxing hierarchy, between a pair of nodes that a TE link does. Note that link bundling is optional and is implementation dependent.

- Support for Control of Hitless Adjustment of ODUflex (GFP)

The control plane should support hitless adjustment of ODUflex, so the routing protocol should be capable of differentiating whether or not an ODU link can support hitless adjustment of ODUflex (GFP) and how many resources can be used for resizing. This can be achieved by introducing a new signal type "ODUflex(GFP-F), resizable" that implies the support for hitless adjustment of ODUflex (GFP) by that link.

As mentioned in Section 5.1, one method of enabling multiplexing hierarchy is via usage of dedicated boards to allow tunneling of new services through legacy ODU1, ODU2, and ODU3 containers. Such dedicated boards may have some constraints with respect to switching matrix access; detection and representation of such constraints is for further study.

5.4. Implications for Link Management Protocol

As discussed in Section 5.3, path computation needs to know the interface switching capability of links. The switching capability of two ends of the link may be different, so the link capability of two ends should be correlated.

LMP [RFC4204] provides a control-plane protocol for exchanging and correlating link capabilities.

Note that LO ODU type information can be, in principle, discovered by routing. Since in certain cases, routing is not present (e.g., in the case of a User-Network Interface (UNI)), we need to extend link management protocol capabilities to cover this aspect. If routing is present, discovery via LMP could also be optional.

- Correlating the granularity of the TS

As discussed in Section 3.1.2, the two ends of a link may support different TS granularity. In order to allow interconnection, the node with 1.25 Gbps granularity should fall back to 2.5 Gbps granularity.

Therefore, it is necessary for the two ends of a link to correlate the granularity of the TS. This ensures the correct use of the TE link.

- Correlating the supported LO ODU signal types and multiplexing hierarchy capability

Many new ODU signal types have been introduced in [G709-2012], such as ODU0, ODU4, ODU2e, and ODUflex. It is possible that equipment does not support all the LO ODU signal types introduced by new standards or documents. Furthermore, since multiplexing hierarchy may not be supported by the legacy OTNs, it is possible that only one end of an ODU link can support multiplexing hierarchy capability or that the two ends of the link support different multiplexing hierarchy capabilities (e.g., one end of the link supports ODU0 into ODU1 into ODU3 multiplexing while the other end supports ODU0 into ODU2 into ODU3 multiplexing).

For control and management consideration, it is necessary for the two ends of an HO ODU link to correlate the types of LO ODU that can be supported and the multiplexing hierarchy capabilities that can be provided by the other end.

5.5. Implications for Control-Plane Backward Compatibility

With the introduction of [G709-2012], there may be OTN composed of a mixture of nodes, some of which support the legacy OTN and run the control-plane protocols defined in [RFC4328], while others support [G709-2012] and the new OTN control plane characterized in this document. Note that a third case, for the sake of completeness, consists of nodes supporting the legacy OTN referenced by [RFC4328] with a new OTN control plane, but such nodes can be considered new nodes with limited capabilities.

This section discusses the compatibility of nodes implementing the control-plane procedures defined in [RFC4328] in support of the legacy OTN and the control-plane procedures defined to support [G709-2012] as outlined by this document.

Compatibility needs to be considered only when controlling an ODU1, ODU2, or ODU3 connection because the legacy OTN only supports these three ODU signal types. In such cases, there are several possible options, including:

- A node supporting [G709-2012] could support only the control-plane procedures related to [G709-2012], in which case both types of nodes would be unable to jointly control an LSP for an ODU type that both nodes support in the data plane.
- A node supporting [G709-2012] could support both the control plane related to [G709-2012] and the control plane defined in [RFC4328].

- o Such a node could identify which set of procedures to follow when initiating an LSP based on the Switching Capability value advertised in routing.
- o Such a node could follow the set of procedures based on the Switching Type received in signaling messages from an upstream node.
- o Such a node, when processing a transit LSP, could select which signaling procedures to follow based on the Switching Capability value advertised in routing by the next-hop node.

5.6. Implications for Path Computation Elements

[RFC7025] describes the requirements for GMPLS applications of PCE in order to establish GMPLS LSP. PCE needs to consider the GMPLS TE attributes appropriately once a Path Computation Client (PCC) or another PCE requests a path computation. The TE attributes that can be contained in the path calculation request message from the PCC or the PCE defined in [RFC5440] include switching capability, encoding type, signal type, etc.

As described in Section 5.2, new signal types and new signals with variable bandwidth information need to be carried in the extended signaling message of path setup. For the same consideration, the PCE Communication Protocol (PCECP) also has a desire to be extended to carry the new signal type and related variable bandwidth information when a PCC requests a path computation.

5.7. Implications for Management of GMPLS Networks

From the management perspective, the management function should be capable of managing not only the legacy OTN referenced by [RFC4328], but also new management functions introduced by the new features as specified in [G709-2012] (for more information, see Sections 3 and 4). OTN Operations, Administration, and Maintenance (OAM) configuration could be done through either Network Management Systems (NMS) or the GMPLS control plane as defined in [TDM-OAM]. For further details on management aspects for GMPLS networks, refer to [RFC3945].

In case PCE is used to perform path computation in OTN, the PCE manageability should be considered (for more information, see Section 8 of [RFC5440]).

6. Data-Plane Backward Compatibility Considerations

If MI AUTOpayloadtype is activated (see [G798]), a node supporting 1.25 Gbps TS can interwork with the other nodes that support 2.5 Gbps TS by combining specific TSs together in the data plane. The control plane must support this TS combination.

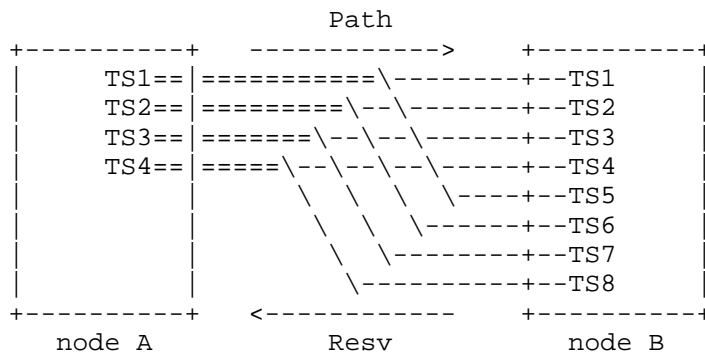

Figure 5: Interworking between 1.25 Gbps TS and 2.5 Gbps TS

Take Figure 5 as an example. Assume that there is an ODU2 link between node A and B, where node A only supports the 2.5 Gbps TS while node B supports the 1.25 Gbps TS. In this case, the TS#i and TS#i+4 (where i<=4) of node B are combined together. When creating an ODU1 service in this ODU2 link, node B reserves the TS#i and TS#i+4 with the granularity of 1.25 Gbps. But in the label sent from B to A, it is indicated that the TS#i with the granularity of 2.5 Gbps is reserved.

In the opposite direction, when receiving a label from node A indicating that the TS#i with the granularity of 2.5 Gbps is reserved, node B will reserve the TS#i and TS#i+4 with the granularity of 1.25 Gbps in its data plane.

7. Security Considerations

The use of control-plane protocols for signaling, routing, and path computation opens an OTN to security threats through attacks on those protocols. However, this is not greater than the risks presented by the existing OTN control plane as defined by [RFC4203] and [RFC4328]. Meanwhile, the Data Communication Network (DCN) for OTN GMPLS control-plane protocols is likely to be in the in-fiber overhead, which, together with access lists at the network edges, provides a significant security feature. For further details of specific security measures, refer to the documents that define the protocols

([RFC3473], [RFC4203], [RFC5307], [RFC4204], and [RFC5440]). [RFC5920] provides an overview of security vulnerabilities and protection mechanisms for the GMPLS control plane.

8. Acknowledgments

We would like to thank Maarten Vissers and Lou Berger for their reviews and useful comments.

9. Contributors

Jianrui Han
Huawei Technologies Co., Ltd.
F3-5-B R&D Center, Huawei Base
Bantian, Longgang District
Shenzhen 518129
P.R. China
Phone: +86-755-28972913
EMail: hanjianrui@huawei.com

Malcolm Betts
EMail: malcolm.betts@rogers.com

Pietro Grandi
Alcatel-Lucent
Optics CTO
Via Trento 30
20059 Vimercate (Milano)
Italy
Phone: +39 039 6864930
EMail: pietro_vittorio.grandi@alcatel-lucent.it

Eve Varma
Alcatel-Lucent
1A-261, 600-700 Mountain Av
PO Box 636
Murray Hill, NJ 07974-0636
USA
EMail: eve.varma@alcatel-lucent.com

10. References

10.1. Normative References

- [G709-2012] ITU-T, "Interface for the Optical Transport Network (OTN)", G.709/Y.1331 Recommendation, February 2012.
- [RFC3209] Awduche, D., Berger, L., Gan, D., Li, T., Srinivasan, V., and G. Swallow, "RSVP-TE: Extensions to RSVP for LSP Tunnels", RFC 3209, December 2001.
- [RFC3471] Berger, L., Ed., "Generalized Multi-Protocol Label Switching (GMPLS) Signaling Functional Description", RFC 3471, January 2003.
- [RFC3473] Berger, L., Ed., "Generalized Multi-Protocol Label Switching (GMPLS) Signaling Resource ReserVation Protocol-Traffic Engineering (RSVP-TE) Extensions", RFC 3473, January 2003.
- [RFC4201] Kompella, K., Rekhter, Y., and L. Berger, "Link Bundling in MPLS Traffic Engineering (TE)", RFC 4201, October 2005.
- [RFC4202] Kompella, K., Ed., and Y. Rekhter, Ed., "Routing Extensions in Support of Generalized Multi-Protocol Label Switching (GMPLS)", RFC 4202, October 2005.
- [RFC4203] Kompella, K., Ed., and Y. Rekhter, Ed., "OSPF Extensions in Support of Generalized Multi-Protocol Label Switching (GMPLS)", RFC 4203, October 2005.
- [RFC4204] Lang, J., Ed., "Link Management Protocol (LMP)", RFC 4204, October 2005.
- [RFC4206] Kompella, K. and Y. Rekhter, "Label Switched Paths (LSP) Hierarchy with Generalized Multi-Protocol Label Switching (GMPLS) Traffic Engineering (TE)", RFC 4206, October 2005.
- [RFC4328] Papadimitriou, D., Ed., "Generalized Multi-Protocol Label Switching (GMPLS) Signaling Extensions for G.709 Optical Transport Networks Control", RFC 4328, January 2006.
- [RFC5307] Kompella, K., Ed., and Y. Rekhter, Ed., "IS-IS Extensions in Support of Generalized Multi-Protocol Label Switching (GMPLS)", RFC 5307, October 2008.

- [RFC5440] Vasseur, JP., Ed., and JL. Le Roux, Ed., "Path Computation Element (PCE) Communication Protocol (PCEP)", RFC 5440, March 2009.
- [RFC6001] Papadimitriou, D., Vigoureux, M., Shiomoto, K., Brungard, D., and JL. Le Roux, "Generalized MPLS (GMPLS) Protocol Extensions for Multi-Layer and Multi-Region Networks (MLN/MRN)", RFC 6001, October 2010.
- [RFC6107] Shiomoto, K., Ed., and A. Farrel, Ed., "Procedures for Dynamically Signaled Hierarchical Label Switched Paths", RFC 6107, February 2011.
- [RFC6344] Bernstein, G., Ed., Caviglia, D., Rabbat, R., and H. van Helvoort, "Operating Virtual Concatenation (VCAT) and the Link Capacity Adjustment Scheme (LCAS) with Generalized Multi-Protocol Label Switching (GMPLS)", RFC 6344, August 2011.

10.2. Informative References

- [G798] ITU-T, "Characteristics of optical transport network hierarchy equipment functional blocks", G.798 Recommendation, December 2012.
- [G872-2001] ITU-T, "Architecture of optical transport networks", G.872 Recommendation, November 2001.
- [G872-2012] ITU-T, "Architecture of optical transport networks", G.872 Recommendation, October 2012.
- [G7041] ITU-T, "Generic framing procedure", G.7041/Y.1303, April 2011.
- [G7042] ITU-T, "Link capacity adjustment scheme (LCAS) for virtual concatenated signals", G.7042/Y.1305, March 2006.
- [G7044] ITU-T, "Hitless adjustment of ODUflex (HAO)", G.7044/Y.1347, October 2011.
- [RFC3945] Mannie, E., Ed., "Generalized Multi-Protocol Label Switching (GMPLS) Architecture", RFC 3945, October 2004.
- [RFC4655] Farrel, A., Vasseur, J.-P., and J. Ash, "A Path Computation Element (PCE)-Based Architecture", RFC 4655, August 2006.

- [RFC6163] Lee, Y., Ed., Bernstein, G., Ed., and W. Imajuku, "Framework for GMPLS and Path Computation Element (PCE) Control of Wavelength Switched Optical Networks (WSONs)", RFC 6163, April 2011.
- [RFC5920] Fang, L., Ed., "Security Framework for MPLS and GMPLS Networks", RFC 5920, July 2010.
- [RFC7025] Otani, T., Ogaki, K., Caviglia, D., Zhang, F., and C. Margaria, "Requirements for GMPLS Applications of PCE", RFC 7025, September 2013.
- [TDM-OAM] Kern, A., and A. Takacs, "GMPLS RSVP-TE Extensions for SONET/SDH and OTN OAM Configuration", Work in Progress, November 2013.

Authors' Addresses

Fatai Zhang (editor)
Huawei Technologies
F3-5-B R&D Center, Huawei Base
Bantian, Longgang District
Shenzhen 518129
P.R. China
Phone: +86-755-28972912
EMail: zhangfatai@huawei.com

Dan Li
Huawei Technologies
F3-5-B R&D Center, Huawei Base
Bantian, Longgang District
Shenzhen 518129
P.R. China
Phone: +86-755-28973237
EMail: huawei.danli@huawei.com

Han Li
China Mobile Communications Corporation
53 A Xibianmennei Ave. Xuanwu District
Beijing 100053
P.R. China
Phone: +86-10-66006688
EMail: lihan@chinamobile.com

Sergio Belotti
Alcatel-Lucent
Optics CTO
Via Trento 30
20059 Vimercate (Milano)
Italy
Phone: +39 039 6863033
EMail: sergio.belotti@alcatel-lucent.it

Daniele Ceccarelli
Ericsson
Via A. Negrone 1/A
Genova - Sestri Ponente
Italy
EMail: daniele.ceccarelli@ericsson.com